

National Grid UK Electricity Transmission plc

Uncontrolled when printed

NATIONAL SAFETY INSTRUCTION and Guidance

NSI 5 CABLE SYSTEMS

Copyright National Grid plc 2016 ©, all rights reserved. No part of this publication may be reproduced, stored in a retrieval system, or transmitted in any form or by any means electronic, mechanical, photocopying, recording or otherwise, without the written permission of National Grid obtained from the issuing location.

The contents of National Grid documents are based on the needs of National Grid and the conditions under which it operates. It shall not therefore be assumed that the contents stated therein necessarily meet the particular circumstances and requirements of other organisations. The principles set out in this document are for information only and therefore National Grid is not liable to any third party for any loss or damage resulting from reliance on the contents. It is the responsibility of such external organisations to check that the document is the latest version and is appropriate for their purposes.

DOCUMENT HISTORY

Issue	Date	Summary of Changes / Reason	Author(s)	Approved By (Title)
1	Oct 2014	Reformatted and re-drafted to follow 4 th Edition Electricity Safety Rules layout and current work practices.	NSI 5 Cable Forum	Mike Dean ETAM Operations Manager North
2	April 2016	Annual review; document amended as detailed below and minor text changes as highlighted in yellow.	NSI Review Group	ETAM Operations North Manager Matt Staley

KEY CHANGES

Section	Amendments
6.1 o (iii) Guidance	Insulating Glove changed from Class 0 to Class 1.
Appendix 4	Authorisation Matrix added

CABLE SYSTEMS

CONTENTS

	Page
1 Purpose and Scope	1
2 Definitions	2
3 Dangers	2
4 General Requirements for Work on Cable Systems	3
5 General Requirements for Work on LV Cables	8
6 General Principles for Work on HV and LV Cables Subject to Impressed Conditions	9
7 Work on HV Cable Sheath Disconnecting Link Boxes and Link Pillars under Impressed Conditions	13
8 Procedure for Cable Serving Test under a Permit For Work	15
9 Work on Metallic Cooling Pipes under Impressed Conditions	16
10 Work on or near Faulty or Damaged HV and LV Cables	16
Fig. 1. An illustration of <i>Insulated Working</i> .	17
Fig. 2. An illustration Depicting the Insulating of Metallic Connections Extending Outside of the Work Area.	18
Fig. 3. An illustration Depicting <i>Earthed Working</i> .	19
Fig. 4. An illustration Depicting Disconnecting Links, in Link Boxes, at turn around Kiosks, Bleed Points and at Terminations.	20
Appendix 1 Guidance on the scope of NSI 5	21
Appendix 2 Guidance on Cable System Hazards	22
Appendix 3 Impressed Conditions Guidance when Working on Cable Systems	29
Appendix 4 Authorisation Matrix	30

1 Purpose and Scope

To apply the principles established by the Safety Rules and provide guidance on National Safety Instruction 5, when applying principles established by the Safety Rules to achieve **Safety from the System** for personnel, working on or near cable systems and their accessories. It incorporates the principles contained within TGN (E) 206 Maintenance and Care of High Voltage Cables.

This instruction shall be applied to all National Grid UK Electricity Transmission cable installations.

This National Safety Instruction (NSI) and guidance note is to be read in conjunction with National Grid Technical Specification 3.05.04 Sheath Bonding and Earthing for Insulated Sheath Power Cables Systems.

For optical fibre cable installations the precautions for working under *Impressed Conditions* need only be considered where the cable is armoured or screened with a metallic or conducting sheath or when a continuous tracer is incorporated into the construction of the cable.

When working on or near cable systems which are associated with railway connections the requirements of Management Procedure NSI 26 - Railway Connection Circuits shall be applied in conjunction with this NSI.

The layout of this guidance note reflects that of legislative codes of practice, where the rule (or mandatory obligation) is identified by a green panel on the left-hand side. The guidance follows after the rule and is identified by a blue panel.

Within National Grid the guidance notes hold equivalent status of an Approved Code of Practice (ACOP) in law. If not followed, you will be required to demonstrate that your safe system of work is of an equal or higher standard.

2 Definitions

Terms printed in bold type are as defined in the Safety Rules.

Title	Definition
<i>Impressed Conditions</i>	Conditions which could cause dangerous induced voltages or currents, differences in earth potential or voltage differences across any break in the conductive path.
<i>Earthed Working</i>	The method of working where all Equipment and conductive materials which are exposed in the work area, are effectively bonded together and then connected to earth at the point of work.
<i>Insulated Working</i>	The method of working where the Person is insulated from contact with objects at different potentials, e.g. local earth.
<i>Co-ordinating Senior Authorised Person</i>	A Senior Authorised Person designated to co-ordinate the work and agrees to the issue of Safety Documents when cable sheath testing is being carried out at the same time as other works on a cable route with multiple sections.
<i>Bonding Connection</i>	A <i>Type Registered</i> form of connection applied at link boxes, joint bays or other points of work to provide an efficient connection to eliminate differences in potential and to carry any current that may arise during fault conditions.
<i>Type Registered</i>	Items of equipment that have been designed, tested and added to a type registered list (TRL).
<i>Overhead Line (OHL) Engineer</i>	A Senior Authorised Person authorised to NSI 4 with sufficient technical qualifications and experience to assess the Drain Earth requirements for induced voltage and current management when appropriate on an Overhead Line.

3 Dangers

The main **Dangers** when working on, or near to, cables and their accessories are electric shock, burns, or other injuries arising from:-

- The possibility of personnel mistaking cables on which it is unsafe to work for those on which it is safe to work
- Voltage difference when the sheath or cores at the point of work are connected to a different earthing area from the one at the point of work, and an earth fault occurs in one of these earthing areas
- Other cables or services within the work area which may be at a different potential
- Induced voltages, or currents, arising from fault, or load currents in other **HV** circuits or Railway Connection Sites
- Induced voltages, or induced currents which may arise when the cable being worked on is connected to an overhead line circuit
- Proximity to exposed **Live Equipment**, other cables or services
- The sudden release of stored energy (e.g. hydraulic fluid) from pressurised cable systems
- Damaged or poor condition cables
- Contact with live cables during excavation
- Inadvertent energisation

NSI 5
4.1 to 4.5

4 General Requirements for Work on Cable Systems

4.1 A **Senior Authorised Person** shall complete a written risk assessment for work on or near to **HV & LV** cable systems. The assessment shall consider whether the cable system(s) to be worked on, including any cable accessories, are subject to *Impressed Conditions*.

4.2 Where *Impressed Conditions* exist, any circulating current shall be managed during the course of the work.

Working under *Impressed Conditions* need not be applied in the following circumstances:

- a where it has been established by calculation, test or existing knowledge that there is no possibility of dangerous *Impressed Conditions* arising
- b when working on communication cables where other codes of practice apply
- c when using **Live** working techniques on **LV** cables

When considering 'a' above, the appropriate recommended voltage limits should be sought from NG TS 3.1.2, TR(E) 468 and TR(E) 476, as well as BS EN 50522 and IEC/TS 60479-1. When necessary, Asset Policy should be consulted regarding the interpretation and application of these documents.

4.3 Cable records shall be used to identify a cable on which work or testing is to be carried out. The identification shall be carried out by the **Senior Authorised Person** issuing the **Permit for Work** or **Sanction for Work** in the presence of the **Competent Person** receiving the appropriate **Safety Document**, who shall be satisfied that the correct cable has been identified.

4.4 The positively identified cable shall be suitably marked at the point of work by the **Senior Authorised Person** issuing the **Permit for Work** or **Sanction for Work**.

4.5 A **Safety Document** shall be issued prior to interference with the cable sheath and associated cable sheath bonding links.

NSI 5
4.6 to 4.8

4.6 Before work involving compromising the primary insulation is carried out on **HV** cables, the cable shall with the exception of the situations identified below, be spiked. Spiking shall be carried out using a spiking gun, under the **Personal Supervision** of the **Senior Authorised Person** issuing the **Safety Document**.

Cable spiking may be omitted in the following circumstances:-

- Where the cable can be visually traced over its whole length from the point of work to a termination where either a **Primary Earth** is applied or the terminal **Equipment** has been proved not to be **Live** and is clearly identified, or
- Where the cable can be visually traced from the point of work to a point on the cable where it has previously been spiked, after which the cable has not been made **Live**, or
- Where the cable can be visually traced from the point of work to a point on the cable which has previously been identified and the cable sheath removed, after which the cable has not been made **Live**.
- When carrying out intrusive work on existing cable joints that have been positively identified

4.7 When a cable is connected to an overhead line it is possible for high induced current to flow in the cable cores or sheath, Section 6.3 of this document shall be applied to the cable. Before any work is carried out in these circumstances advice shall be sought from an *OHL Engineer*.

4.8 When a cable is terminated into gas insulated switchgear (GIS) consideration shall be given to the effects of impressed voltages being present on the switchgear side of the termination.

Guidance
NSI 5
4.1 to 4.2

4 General Requirements for Work on Cable Systems

- 4.1 A **Senior Authorised Person** not authorised to NSI 5 is not precluded from undertaking a written risk assessment for work on or near to **LV** cable systems within one earthed system. When the **Senior Authorised Person** carrying out the risk assessment deems it necessary to seek further guidance or the work is on or near **HV** cable systems advice from a **Senior Authorised Person** authorised to NSI 5 shall be obtained.

When completing the risk assessment the **Senior Authorised Person** shall fully assess the work to be done in relation to the entire cable route.

HV & LV cables between interconnected or separately earthed systems can be subject to *Impressed Conditions*. The requirements of Section 6 - General Principles for Work on **HV** and **LV** Cables Subject to Impressed Voltages shall be applied.

Measurements have shown that **HV** cables contained within one earthed system can be subject to *Impressed Conditions*. The requirements of Section 6 General Principles for Work on **HV** and **LV** Cables Subject to Impressed Voltages shall be applied.

LV multi-core auxiliary cables within one earthed system are not normally subject to *Impressed Conditions*. If the risk assessment determines that *Impressed Conditions* will not be present then Section 6 General Principles for Work on **HV** and **LV** Cables Subject to Impressed Voltages does not apply and work may proceed under an appropriate Management Procedures.

- 4.2 When working on **HV** cables, the impact of *Impressed Conditions* from adjacent live circuits shall be assessed and a path for any circulating current shall be maintained.

There are four ways to carry out the work:

(i) With Circulating Currents and Earthed at Point of Work

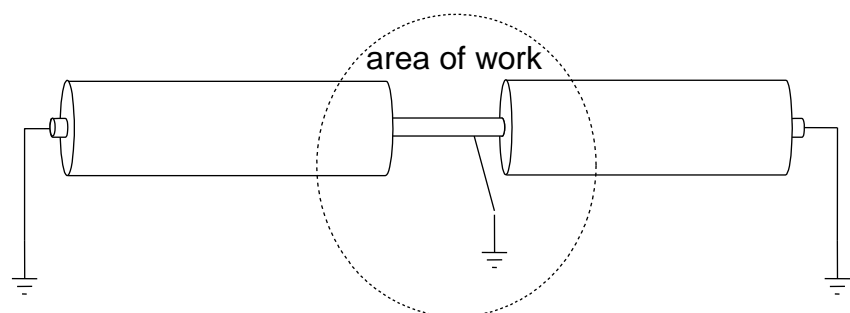

Guidance
NSI 5
4.2 Cont.

(ii) With Circulating Currents and Insulated at Point of Work

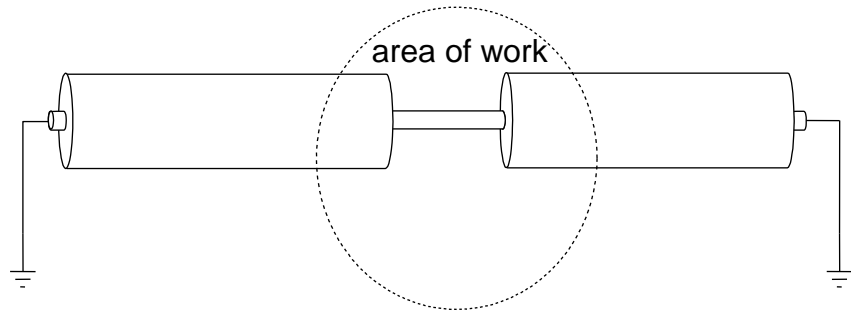

(iii) No Circulating Currents and Earthed at Point of Work

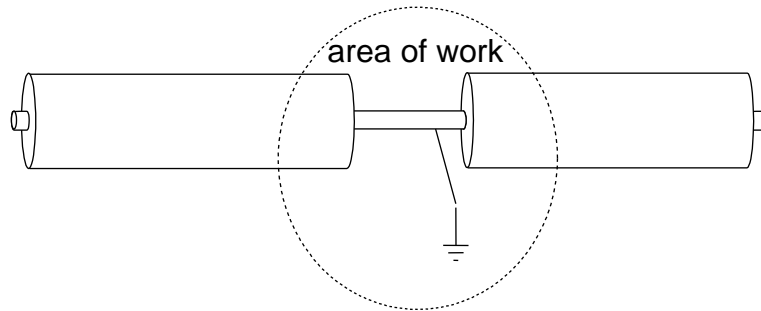

(iv) No Circulating Currents and Insulated at Point of Work

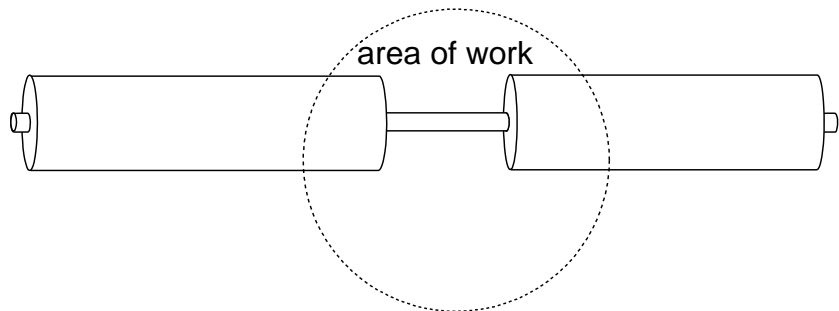

Studies have shown that for cable sheath components, there is a potential for circulating currents up to 150A to be present during steady state conditions and 2kA under fault conditions.

Additionally, for cable core components, the potential for circulating currents up to 200A during steady state conditions and 2kA under fault conditions is possible.

Any equipment used for the management of these circulating currents shall be of adequate strength and capability.

Guidance

4.3 If the cable records alone are insufficient to identify a cable, the cable

NSI 5
4.3

shall be positively identified by using either method a or method b below:

- a Imposing a signal on it from an identified point and verifying positively the presence of the signal at the position where it is proposed to cut the metallic sheath. Care must be taken to ensure that the signal is genuine and not induced.
- b Utilising the following process
 - (i) Verify the integrity of the cable oversheath on the cable requiring identification.
 - (ii) Using *Insulated Working* a section of the oversheath should be removed at the position where the work requiring the cutting of the metallic sheath is to be carried out.
 - (iii) A *Bonding Connection* must then be applied to the exposed metallic sheath and connected to the common earth bar via the Bridling Bar.
 - (iv) Carry out an oversheath test on the cable to be worked upon. The objective of the test is to confirm the presence of the *Bonding Connection* at the position where the cutting of the metallic sheath is to be carried out. This will be indicated by the operator of the test set being unable to raise the test voltage and at the same time the Ammeter of the set indicating the passage of high current.
 - (v) Disconnect the oversheath test equipment.
 - (vi) At the position where the metallic sheath is to be cut and removed use *Insulated Working* to remove the *Bonding Connection* previously applied as detailed in (iii) above.
 - (vii) Carry out an oversheath test on the cable to be worked upon. The objective of the test is to confirm that the removal of the *Bonding Connection* where the cutting of the metallic sheath is to be carried out enables the operator of the test set to raise the test voltage to the value required by the work specification. The Ammeter on the test set should only indicate the passage of a low value of milli-amperes consistent with the normal oversheath test value. If the operator is not able to raise the voltage and high current still flows through the milliamp meter then this indicated the presence of an earth path additional to that provided by the previously applied *Bonding Connection*. This may be a genuine oversheath fault or an inadvertent earth elsewhere on the metallic sheath or bonding system on the section under test. In such circumstances the **Senior Authorised Person** shall consider the test results and decide whether the results have unambiguously identified the metallic sheath to be worked on as the correct cable.

Guidance
NSI 5
4.3 Cont. to 4.8

- 4.5 A documented means of identifying which links have been removed and subsequently replaced shall be produced by the **Senior Authorised Person** issuing the **Safety Document**.
- 4.6 Spiking shall be carried out using an appropriate manufactured device such as those supplied by Accles & Shelvoke.
- 4.7 The requirements of rule 4.7 cannot be applied whilst the disconnection or re-connection is being carried out.
- 4.8 Work on **HV** cables and associated cable sealing ends is subject to the requirements of NSI 5. Connecting or disconnecting **HV Equipment** to cable sealing ends, such as GIS chambers and **HV** busbars, may be subject to *Impressed Conditions* from the cable, authorisation to this NSI is not required to complete this work; however a **Senior Authorised Person** appointed to this NSI shall be consulted before work commences to ensure management of *Impressed Conditions* is considered and actioned where appropriate.

NSI 5
5.1 to 5.5

5 General Requirements for Work on LV Cables

- 5.1 All work shall be carried out in accordance with a Management Procedure.
- 5.2 A combination of cable records and testing shall be used to identify a cable on which work or testing is to be carried out.
- 5.3 Exceptions to the requirements of 5.2 are where the cable can be physically traced to the point of work from:-
 - a) The **Point(s) of Isolation**, or
 - b) A previous point of work where the cable has been proved, and remained, **Dead**.
- 5.4 The **Senior Authorised Person** issuing the **Safety Document** shall suitably mark the positively identified cable at the point of work.
- 5.5 Until the cores of the cable have been checked and confirmed **Dead**, the cable shall be treated as **Live**. The cable sheath and insulation shall be removed using **Live** working techniques, by a competent person. Once the cores have been proved **Dead**, there is no need to use **Live** working techniques.

Guidance
NSI 5
5.1 to 5.5

5 General Requirements for Work on LV Cables

- 5.1 The Management Procedure for **LV** cables is NSI 12 – ‘Low Voltage Equipment’.
- 5.2 If cable records alone are insufficient to identify a cable, the cable shall be positively identified by imposing a signal on it from an identified point. The signal shall then be identified at the point of work using a detector. Care shall be taken that the signal is genuine and not induced.
- 5.5 Instruments and associated tests leads shall be fuse (or equivalent) protected and provided with suitably insulated probes and test leads.

NSI 5
6.1 to 6.4

6 General Principles for Work on HV and LV Cables Subject to Impressed Conditions

- 6.1 *Earthed Working* shall, where reasonably practicable be applied. Where this is not reasonably practicable, or is undesirable, *Insulated Working* can be adopted as an alternative.
- 6.2 Where it is necessary to disconnect **LV** cable terminations, to establish **Point(s) of Isolation**, this shall be done using *Insulated Working*.
- 6.3 When working on a cable system which is connected to an overhead line, the cable shall be disconnected from the overhead line or the induced current shall be managed by earthing.
- 6.4 When working on the metallic sheath of cable where an induced current may be present, the cable sheath earth system links at the remote ends of each section to be worked on shall be removed before commencing work. To avoid **Danger** each link shall be connected to earth using a *Type Registered* bonding lead before it is removed or replaced.

Guidance
NSI 5
6.1

6 General Principles for Work on HV and LV Cables Subject to Impressed Conditions

- 6.1 If the work is to be carried out using *Earthed Working*, the precautions given below shall be applied:-
- a) *Earthed Working* may be achieved by the use of *Type Registered* Earth Bonds.
 - b) With the exception of the cores sheaths or armour to be worked on, all exposed metallic pipes, bracings, etc., within the work area and with which contact is possible, shall be connected to a common earth bar. This is shown in Figure 3.
 - c) If any part of the work is to be carried out using *Earthed Working*, an earth screen, connected to the common earth bar, shall be provided to extend outside the work area at the point of access for a distance of a least one metre. If the work area has no local earth, the common earth bar shall be connected to an alternative earth. Any subsequent earthing to the cable at this point of work shall be taken from this bar.
 - d) Consideration shall be given to the environmental conditions under which insulated equipment is used. Excessive water or mud may compromise the insulating properties of the equipment.
 - e) Under *Impressed Conditions*, the potential of the work area earth system may rise above that of the local mass of earth. If metallic connections such as cables or pipes extend from within the work area earth system to equipment outside that earth system, a hazard could exist to persons inside and outside the work area. All such metallic connections shall have an insulating section so that a person cannot make simultaneous contact with two earth systems. A typical cable joint bay situation is shown in Figure 2.

Guidance
NSI 5
6.1 Cont.

- f) Metalwork on the work area side of the insulating section shall be connected to the common earth bar. Earthed metalwork on the external side of the insulating section shall be connected to a separate external earth system.
- g) External insulation shall be applied to exposed metalwork and pipes near the boundary of the work earth screen so that persons in contact with the earth screen cannot make simultaneous contact with metalwork connected to the separate external earth system. Alternatively, the earth screen near the boundary can be covered with an insulating sheet or mat.
- h) Electrical supplies utilised in the work area shall be via an isolating transformer.

If the work is to be carried out using *Insulated Working*, the precautions given below shall be applied:-

- i) With the exception of the cores, sheaths or armour to be worked on, all exposed metallic pipes, bracings, etc., within the work area and with which contact is possible, shall be wrapped with insulating sheet. This is shown in Figure 1.
- j) Consideration shall be given to the environmental conditions under which earthing equipment is used. Excessive water or mud may compromise the surface contact performance of the earthing equipment.
- k) Under *Impressed Conditions*, the potential of the work area earth system may rise above that of the local mass of earth. If metallic connections such as cables or pipes extend from within the work area earth system to equipment outside that earth system, a hazard could exist to persons inside and outside the work area. All such metallic connections shall have an insulating section so that a person cannot make simultaneous contact with two earth systems. A typical cable joint bay situation is shown in Figure 3.
- l) Metalwork on the work area side of the insulating section shall be connected to the common earth bar. Earthed metalwork on the external side of the insulating section shall be connected to a separate external earth system.
- m) External insulation shall be applied to exposed metalwork and pipes near the boundary of the work earth screen so that persons in contact with the earth screen cannot make simultaneous contact with metalwork connected to the separate external earth system. Alternatively, the earth screen near the boundary can be covered with an insulating sheet or mat.
- n) Electrical supplies utilised in the work area shall be via an isolating transformer.

Guidance
NSI 5
6.1 Cont.

o) *Insulated Working* may be achieved by the use of an Insulated Platform or alternatively by using a combination of at least two of the following items:-

- (i) Insulating mat
Capable of withstanding a test voltage of 15kV (rms) for 1 minute
- (ii) Insulating boots
An oil resistant boot, to BS EN 50321, capable of withstanding a test voltage of 20kV
- (iii) Insulating gloves
A gauntlet type glove, class 1 in accordance with BS EN 60903, capable of withstanding a test voltage of 10kV peak
- (iv) Insulated tools
Insulated tools shall be insulated to a 10kV test level
- (v) Insulating sheet
3mm thick clear PVC or equivalent thickness with one or more sheets, capable of withstanding a test voltage of 15kV (rms) for 1 minute

All equipment shall be inspected for damage or defect immediately before use. Any equipment found faulty shall be withdrawn from service.

p) Persons carrying out *Insulated Working* shall not accept materials from, or make physical contact with, anyone outside the insulated environment.

Guidance
NSI 5
6.3 to 6.4

6.3 Any disconnection between the overhead line and cable shall be achieved by, disconnecting the associated overhead line downleads, down droppers or busbars connecting to the cables sealing ends. Primary earths are to be initially connected to the circuit at the remote ends.

If not disconnected, Earthing shall be used to manage induced current from the overhead line, appropriately rated **Earthing Devices** shall be applied between the OHL and the point of work to either the overhead line downleads, droppers, or the busbars connecting to the cable sealing ends on all phases.

The Earthing Device/s must be capable of withstanding the continuous induced current rating, which can be up to 450A (900A in a complex circuit).

The number of portable **Earthing Devices** needed to manage the induced currents on the circuit to be worked upon can be found within Appendix A.10 of NSI 2 Guidance Notes, using the "Line End Equipment" column for the relevant substation. On circuits where the cable section is mid route of an OHL (i.e. the cable is not directly connected to the substation), then the number of portable **Earthing Devices** needed to manage the induced currents at that point shall be the higher of the circuit interconnecting substations requirements.

The earth shall be of adequate strength and capability to provide an efficient connection between earth and the HV equipment, and capable of safely discharging any resultant fault current due to inadvertent energisation.

A 'Competent Person', or a 'Person' under their personal supervision, may apply and remove the earth in accordance with an Earthing schedule under a safety document.

When/where present a fixed Earthing Device shall be used rather than a portable one.

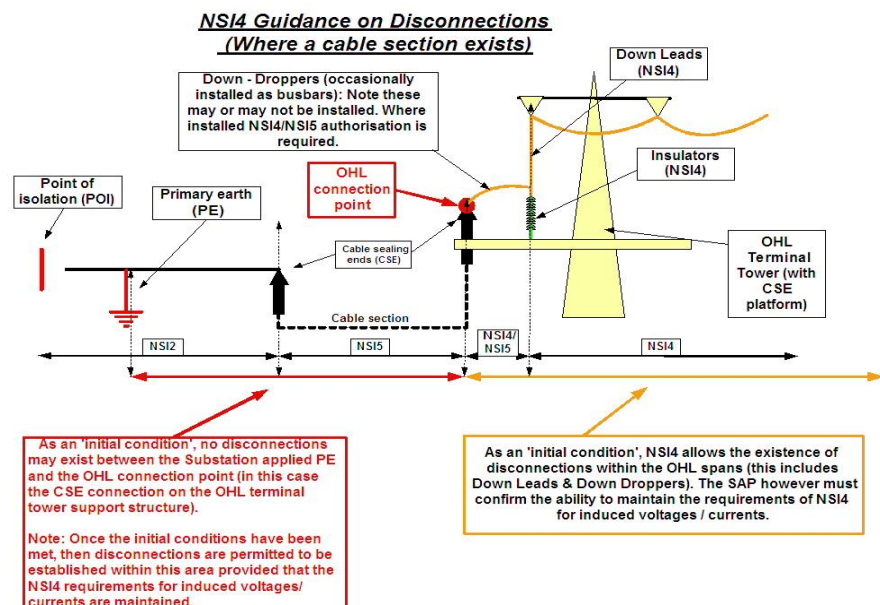

Figure 6.3 A

Guidance
NSI 5
6.4 cont.

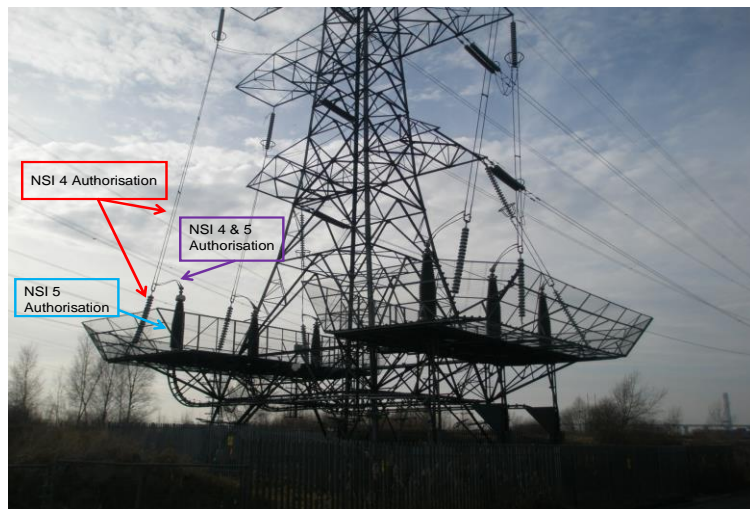

Figure 6.3 B

6.4 When cable sheath links have been removed the cable may be subject to *Impressed Conditions*. The method for dealing with this condition shall be addressed in the method statement.

NSI 5
7.1 to 7.2

7 Work on HV Cable Sheath Disconnecting Link Boxes and Link Pillars under Impressed Conditions

7.1 Until such time as *Earthed Working* conditions have been established, the fitting or removal of disconnecting links, Sheath Voltage Limiters (SVL) connections or *Bonding Connections* shall be carried out using *Insulated Working* in accordance with the requirements laid out in Section 6.1.

7.2 Where the facility exists, link boxes shall be **Locked** after each operation and a warning notice attached. This warning notice shall not be removed until work has been completed, the links returned to the normal operating position and the box finally **Locked**.

Guidance
NSI 5
7.1 to 7.2

7 Work on HV Cable Sheath Disconnecting Link Boxes and Link Pillars under Impressed Conditions

7.1 In most cases the carcass of a link pillar may be connected to a local earth and not connected to the earth associated with the cable sheaths. These separate earth systems should not be connected. Working on links and SVL's in link pillars should be carried out using *Insulated Working*.

In link boxes not fitted with special connecting points for the attachment of *Bonding Connections*, it may be necessary to adjust or remove the links prior to the fitting of *Bonding Connections*. This shall be done using *Insulated Working*.

Where it is not possible to connect the earth end fitting of the *Bonding Connection* to the earth pillar or to the external earth connections of the link box, *Insulated Working* shall be adopted.

7.2 An example of a Work in Progress Under Induced Voltage Conditions sign.

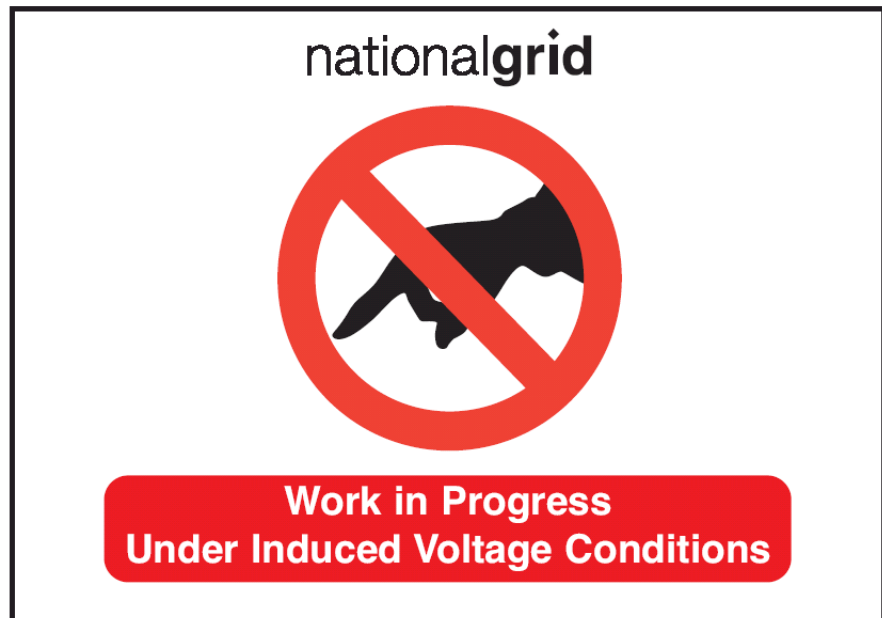

Figure 7.2 A - Work in Progress Under Induced Voltage Conditions sign.

NSI 5
8.1 to 8.4

8 Procedure for Cable Serving Test under a Permit For Work

- 8.1 During testing other work may be undertaken on a cable, provided the **Working Party** is separated from testing teams by one major section, and the work to be undertaken will not be affected by the testing.
- 8.2 Each testing team shall be issued with its own **Permit for Work** clearly designating the work **Location(s)**.
- 8.3 The **Competent Person** in charge of the testing will ensure that the testing team is at the correct **Location** identified on the **Permit for Work**.
- 8.4 The **Competent Person** shall ensure that the point of test is always attended during testing.

Guidance
NSI 5
8.1 to 8.4

8 Procedure for Cable Serving Test under a Permit For Work

- 8.1 **PROCEDURE FOR MAINTAINING ONE MAJOR SECTION ISOLATION BETWEEN WORKING PARTIES DURING CABLE SHEATH TESTING**
- a) To prevent overlap and maintain continuity of work one **Senior Authorised Person** will be designated as the co-ordinating **Senior Authorised Person** for each cable circuit outage. All **Safety Documents** shall be issued with their knowledge and agreement.
- b) One **Isolated** and **Earthed** Major Section shall be maintained between each testing team and any other **Working Party**.
- c) The co-ordinating **Senior Authorised Person** shall issue a **Permit for Work** to remove links and disconnect SVL's from the cross bonding link boxes / pillars within the major section. The link boxes / pillars shall be secured with unique locks, the keys being held in the safe custody of the co-ordinating **Senior Authorised Person**.
- d) On completion of c) above the co-ordinating **Senior Authorised Person** can agree the issue of **Safety Documents** on the adjacent sections to the Major Section.
- e) The link boxes/pillars shall remain **Locked** until **Safety Documents** on the adjacent sections have been cancelled.
- 8.4 At the point of test adequate provision shall be made to prevent unauthorised access and contain the test equipment.

NSI 5
9.1

9 Work on Metallic Cooling Pipes under Impressed Conditions

- 9.1 At the planning stage a request should be made to have the associated cable out of service.

Guidance
NSI 5
9.1

9 Work on Metallic Cooling Pipes under Impressed Conditions

- 9.1 Work on metallic cooling pipes under *Impressed Conditions* shall, where reasonably practicable be carried out with the associated cable out of service.

Where it is necessary to work on metallic cooling pipes under *Impressed Conditions*, with the associated cabling in service, a **Senior Authorised Person** shall specify the means to avoid **Danger**.

Insulated Working, in accordance with the guidance contained in 6.1, shall be applied for all operations involving: disconnecting links, in link boxes, at turn round kiosks, bleed points and at termination see Figure 4.

NSI 5
10.1 to 10.3

10 Work on or near Faulty or Damaged HV and LV Cables

- 10.1 Work shall never take place on or near **Live HV** cables, where **Danger** may arise.
- 10.2 Before work starts on or near a faulty or damaged **HV** cable it shall be positively identified and proved **Dead**. Identification shall include reference to cable records and the use of a cable identifier. Proving **Dead** should be by spiking with a spiking gun.
- 10.3 Work on faulty or damaged **LV** cables should preferably be carried out with the cable **Dead**. **Live** work on faulty or damaged **LV** cables shall never take place where **Danger** may arise.

Guidance
NSI 5
10.1 to 10.3

10 Work on or near Faulty or Damaged HV and LV Cables

- 10.1 The appearance of a cable is no guarantee of its conditions. No assumptions should be made that a cable with exposed conductors is **Dead**. This includes cables which have been badly damaged.
- 10.2 Spiking shall be carried out using an appropriate manufactured device such as those supplied by Accles & Shelvoke.
- 10.3 It may be necessary to carry out tests on faulty or damaged **LV** cables while they are **Live** to locate the fault. Once the location of a fault on a **LV** cable has been determined, work to repair it shall be carried out with the cable **Dead**.

Figure 1. An illustration of *Insulated Working*.

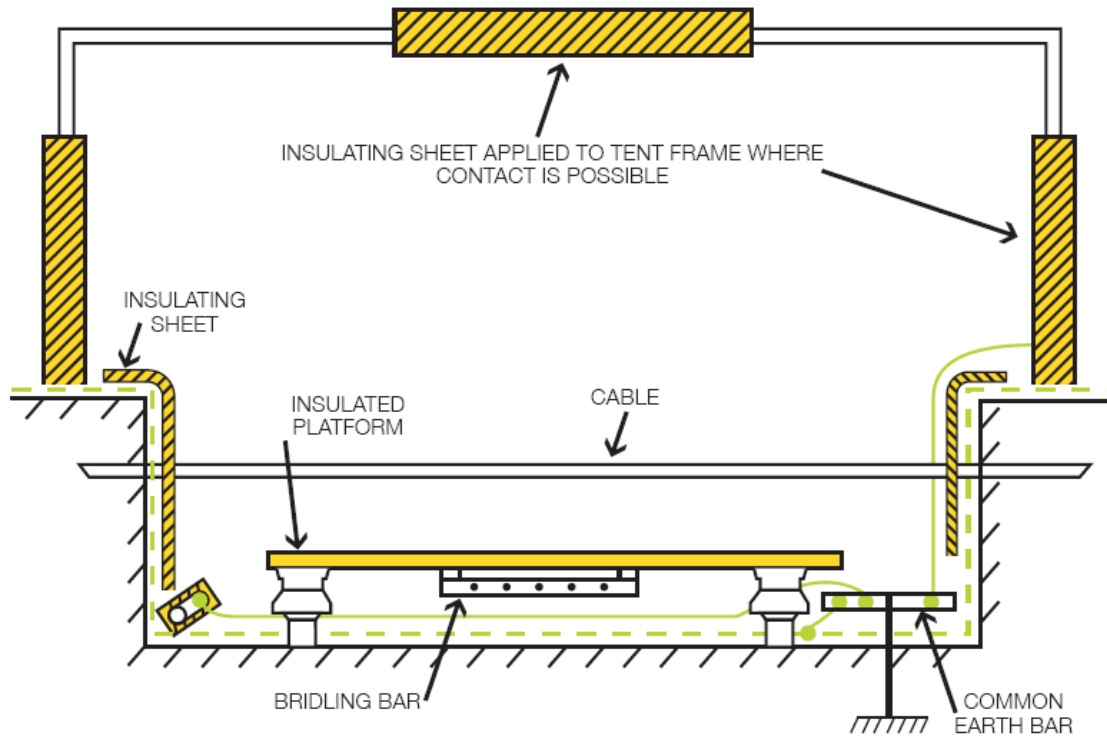

A photograph of a bay set up for *Insulated Working*.



Figure 2. An illustration depicting the insulating of metallic connections extending outside of the work area.

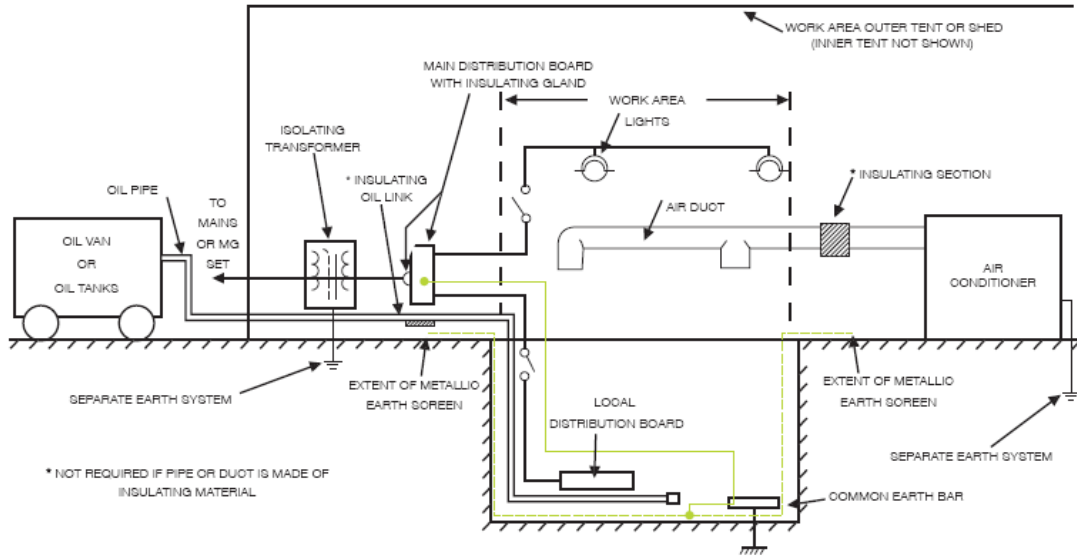
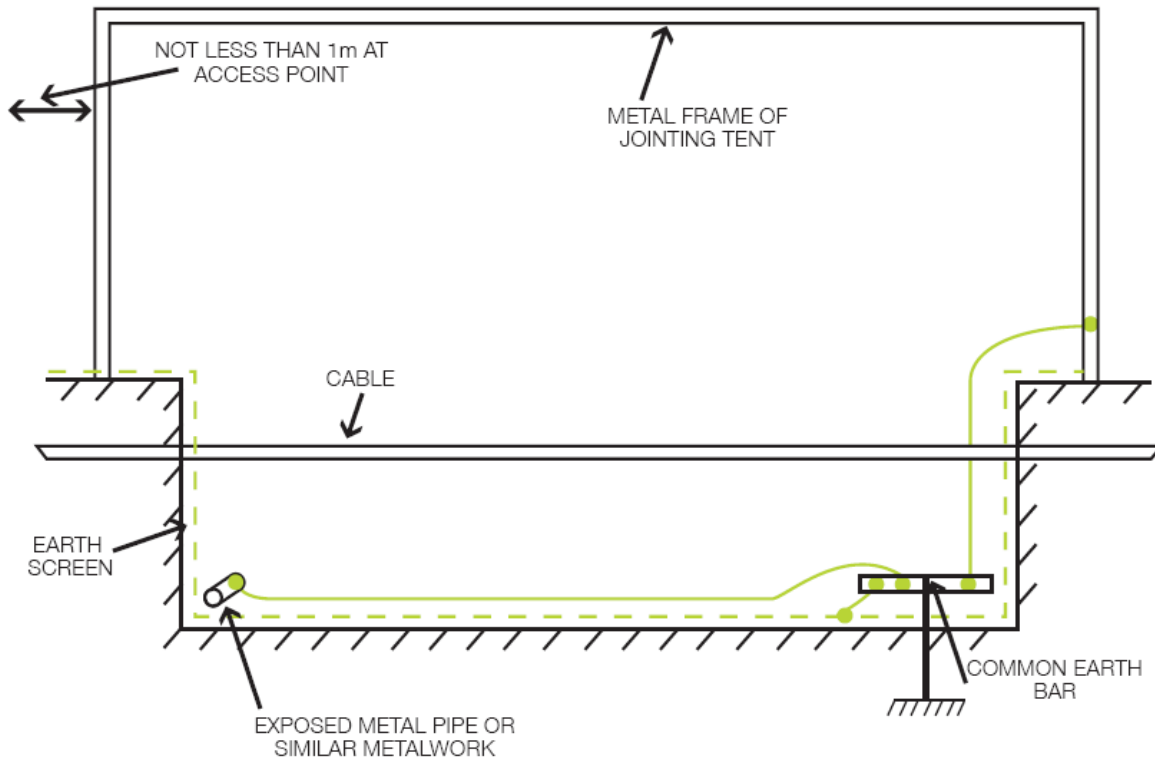

Figure 3. An illustration depicting *Earthed Working*.



A photograph of a bay set for *Earthed Working*.



Figure 4. An illustration depicting disconnecting links in link boxes, at turn around kiosks bleed points and at terminations.

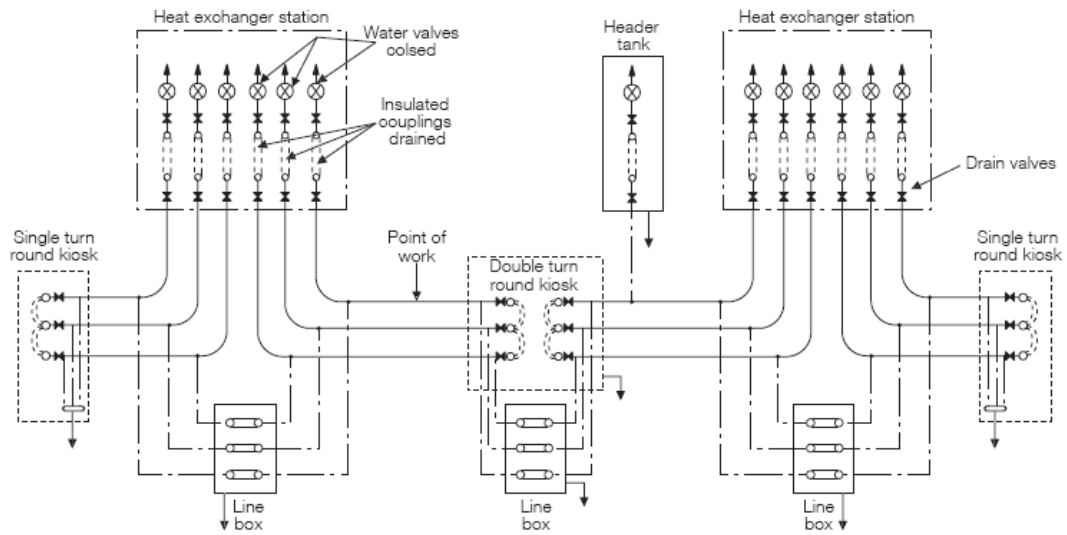

Appendix 1 - Guidance on the scope of NSI 5.

The scope of NSI 5 includes not only the cable but also any **Equipment** electrically connected (not via an earth) to the cable as current may be circulating in or voltage may be transferred onto the connected **Equipment**.

The **Equipment** affected by the requirements of NSI 5 is illustrated in Figure 1.

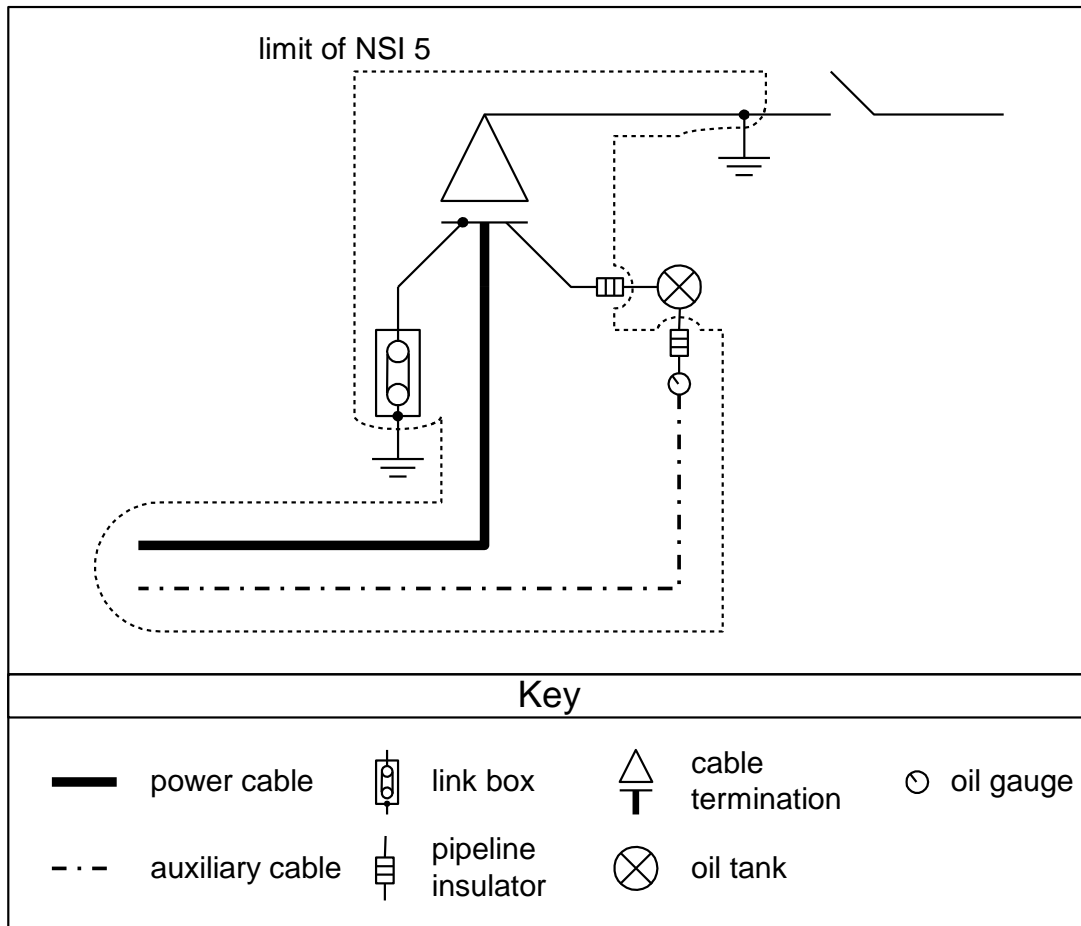

Figure 1 Scope of NSI 5.

Referring to Figure 1, a number of features are observed. Auxiliary cables are included within the scope of NSI 5 as induced voltages or transfer of earth potential rise affect auxiliary cables. Oil tanks are outside the scope of NSI 5 since pipeline insulators isolate the oil tanks. Note that while the earths of cable systems are outside the scope of NSI 5, that currents circulating in cables can be returned via the earth and that the requirements of NSI 24 need to be met.

Appendix 2 – Guidance on Cable System Hazards.

When working on or near any conductive equipment (metal or semi-conducting material) that is either part of a cable or electrically connected to a cable (other than via an earth), a number of different hazards arise from the **System**. An assessment of the risk from each of these hazards should be made and the appropriate control measures should be taken to mitigate the risk.

The following generic hazards may be encountered and examples of their occurrence are given in the proceeding text.

- Direct connection to **System** voltage (including infringing **Safety Distance**)
- Induced currents and voltages (inductive)
- Transfer of earth potential rise
- Capacitive coupling

While risks from capacitive coupling are generally lower than on other conductor systems, there is still a potential for capacitive coupling.

- Trapped charge and dielectric polarisation

If the cable insulation has been exposed to a DC voltage for a length of time, the insulation can become polarised. This can happen when a cable has been switched out and has trapped charge although is more likely following a sheath test. When the insulation has become polarised, a voltage may appear on conductive parts of the cable system even after it has been earthed and the earth is removed.

- Stray Currents (return current on single phase systems)

Single or two phase systems are typically used on railway systems. These systems are outside the scope of this guidance.

- Stray Currents from connected overhead lines

Where a cable system is connected to an overhead line and there is no earth connection between the conductor of the overhead line and the conductor of the cable, induced currents in the overhead line may be carried by the conductor of the cable and return via an earth path such as the cable sheath or other parallel earthed conductor.

Direct connection to **System** voltage (including infringing **Safety Distance**)

There is always a risk from direct connection to the **System** or exceeding the electrical strength of insulation.

Since work on cable systems is often mid route where the isolation and earthing of the **Equipment** being worked on is not obvious NSI 5 makes extra requirements in addition to those made in NSI 2 regarding the identification of circuits being worked on.

Induced currents and voltages (inductive)

Cable systems running parallel to other conductor systems that carry current will be inductively coupled to these systems; this mutual inductance may under certain circumstances create a hazardous risk from uncontrolled voltages or current in the cable system or connected **Equipment**. The current in the parallel circuits will generate a magnetic field and this magnetic field will impinge on the cable system. The magnetic field as it changes (due to the AC current in the parallel conductor system) will then have the potential to generate a current or voltage within the cable system.

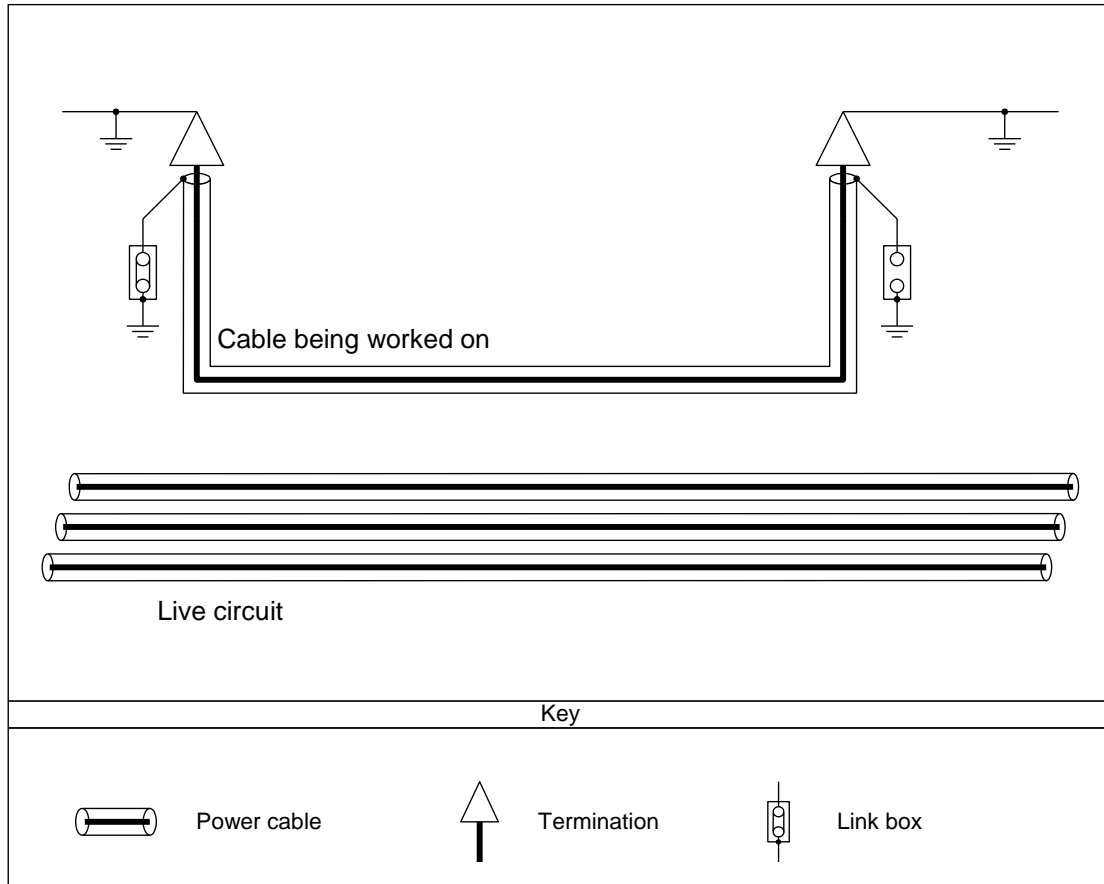

Figure 2 Induced currents and voltages.

For example consider the cable in Figure 2 that is running parallel to another conductor system, in this case a second cable system. The current in the parallel circuit will induce a voltage in the cable sheath as one end is **Earthed** and the other floating. This is as the current in the parallel circuit sets up a magnetic field that interacts with cable sheath. Hence any work on the cable sheath will need to take account of induced voltages, for example by working under NSI 5 *Impressed Conditions* insulated working at the remote end. It should be noted that if the cable sheath is not **Earthed** at either end, it will still have an induced voltage.

The current in the parallel circuit will also induce a current in the conductor of the cable. Care should be taken in not breaking the current path and hence work on the conductor should be undertaken under NSI 5 *Impressed Conditions Earthed Working*.

It should be noted induced voltages and currents will, under abnormal condition such as short circuit or switching transients, be much greater than normal.

Transfer of Earth Potential Rise (EPR)

When working on a cable system connected to a remote earth there is the risk that the remote and local earths are at different potentials.

Cable systems often run outside a single earth mat. In such situations consideration has to be given to the existence of the transfer of EPR. The problem can occur when there is a fault on one part of the system that will cause the earth at the location to have an EPR. The cable will transfer this EPR to another location that has a different earth potential. Therefore there can be a voltage between two “**Earthed**” objects.

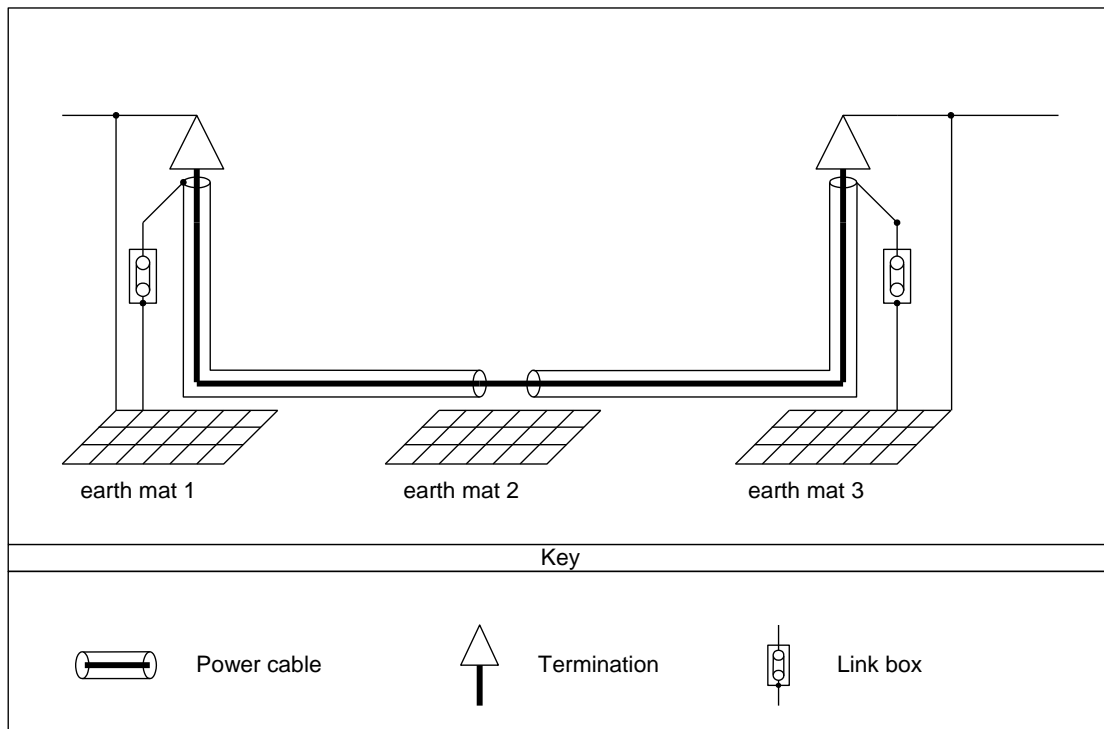

Figure 3 Transfer of earth potential rise.

An example is given in Figure 3 where work is being conducted at a joint bay in the middle of a route. If there is a fault at one of the earth mats, say earth mat 3, then there is the possibility for the voltage at the other earth mats to be different. As such, either the work has to be carried out under NSI 5 *Impressed Condition* insulated working or all the metal components of the cable have to be earthed to the local earth mat.

Capacitive coupling

Unearthed metal parts of a cable system near to high voltage conductors can become capacitively coupled to the high voltage conductor. This is as an unearthed metal object in an electrical field will pick up a voltage. Normally cables are buried and as the ground is at earth potential the cable is effectively shielded from any high voltage conductors. However there are times when a cable system is exposed to electric fields. It should be noted that only a part of the cable system needs to be exposed to the electric field for the whole cable to be affected.

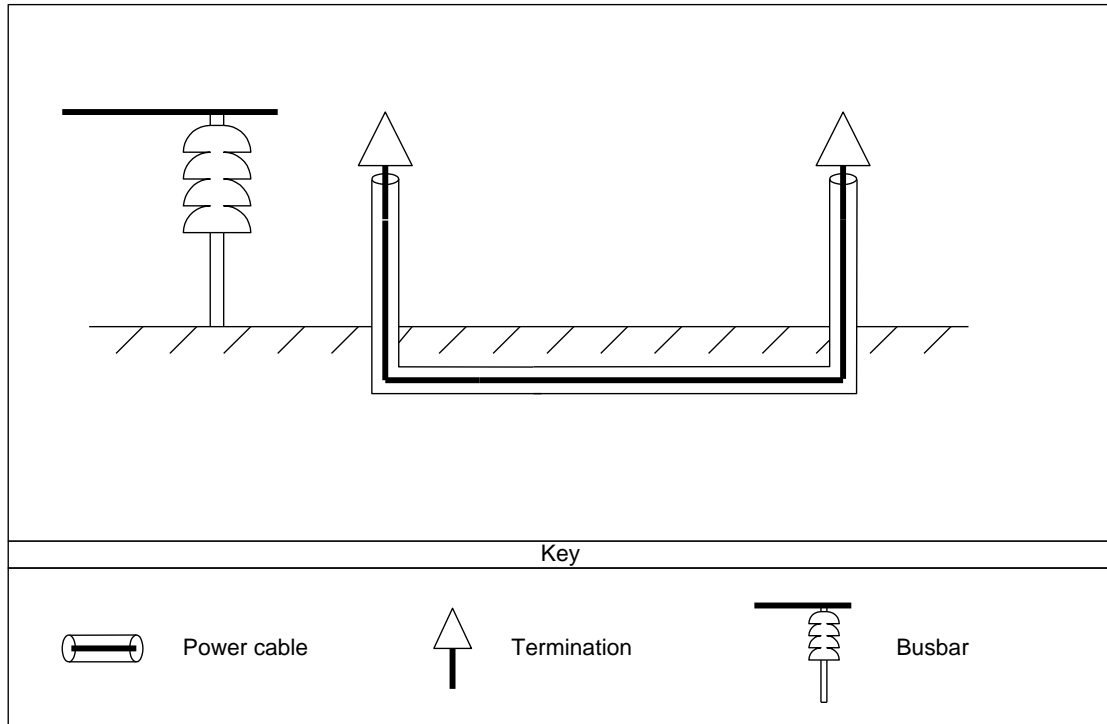

Figure 4 Capacitive coupling.

In Figure 4 a buried cable system that is disconnected from the **System** and any earths is shown. At one end of the route the termination is close to an energised busbar and is therefore within the electrostatic field generated by the busbar. The metal parts of the cable will pick up a voltage from the field so that a voltage will appear on cable.

Trapped charge and dielectric polarisation

The cable design, with layers of metal conductors separated by insulation, makes the cable an effective capacitor. A simplified cross section of a cable is shown in Figure 5. It should be noted that in addition to the capacitance between the conductor and metal sheath, there is also a capacitance between the metal sheath and semi-conducting outer layer. It is possible that a DC voltage can be left on the cable resulting in trapped charge. Typically this can happen if the circuit is switched out and the circuit breaker does not open exactly at the pole zero. For long circuits a discharge voltage transformer is fitted to discharge this trapped charge.

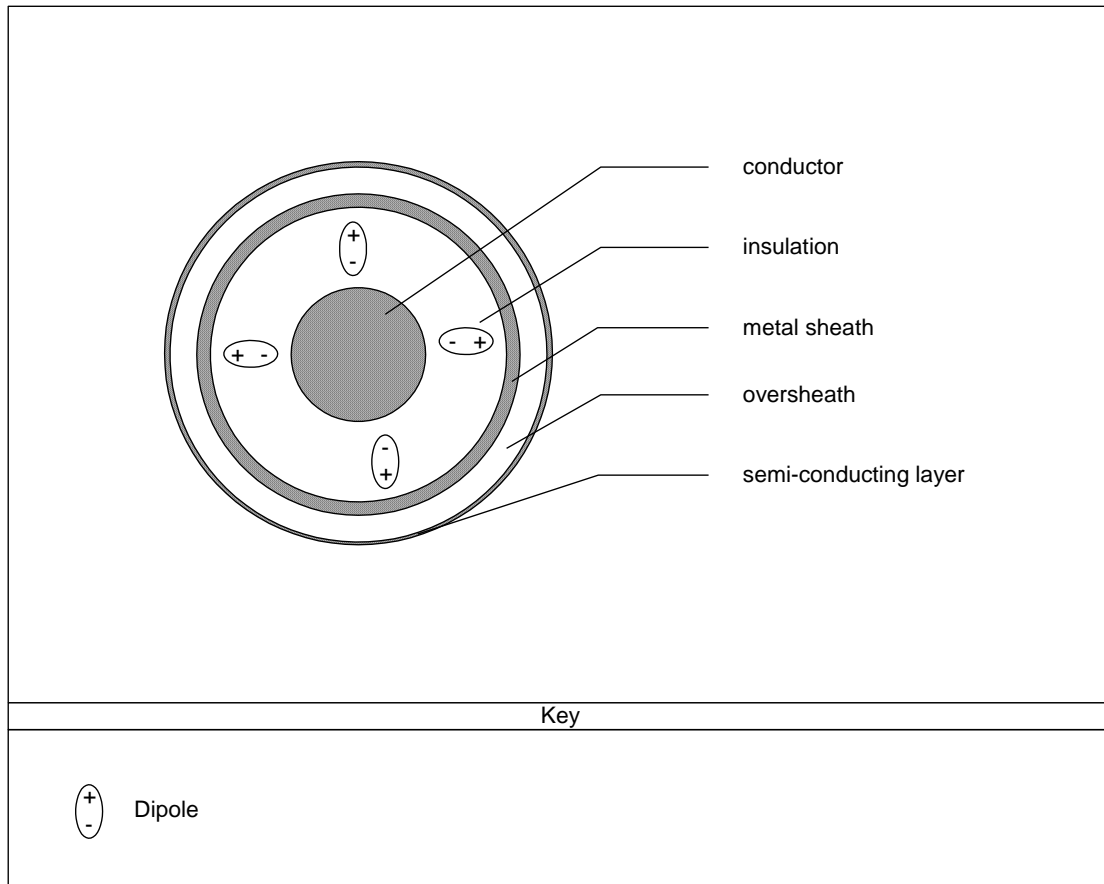

Figure 5 Simplified cable cross section.

A second related phenomenon known as polarisation can occur if the cable is left with DC voltage for a length of time. Polar molecules are molecules that while electrically neutral overall have parts that are more positive and parts that are more negative. A common example is water that is more positive at one end and more negative at the other forming a dipole. Such molecules if they are in a cable with DC voltage will align themselves to the electric field. An example is given in Figure 5 with the conductor being at a positive voltage, the negative ends of the dipole will be attracted to the conductor. It takes some time for polarisation to develop and it also takes time for polarisation to dissipate. If insulation has become polarised, it can happen that the object can be earthed briefly and when the earth is removed the polarisation is still present and this re-establishes a voltage on the object. PVC is particular prone to these effects and care has to be taken following a DC sheath test that the sheath is properly earthed for some time to allow the oversheath to depolarise fully.

Stray currents (return current on single phase systems)

Single phase systems are typically installed for use on railway systems. In such systems the return conductor is normally earthed at both ends of the route. Any **Earthed** parallel conductor (e.g. cable sheath) installed near a single phase cable may carry the return current instead of the return conductor. This phenomenon is termed as Alternative Conductor Return in NSI 26. Such cable systems are complex and NSI 26 as well as site specific safety instructions exist for these systems.

Stray currents from connected overhead lines

Any work with cables connected to overhead lines should take account of NSI 4. When an out of service overhead line circuit is connected to a cable with earths at both ends of the route considerable stray induced current from the overhead line can be present in the cable system. This stray current can be up to 450A (900A in a complex circuit). The arrangement is shown in Figure 6.

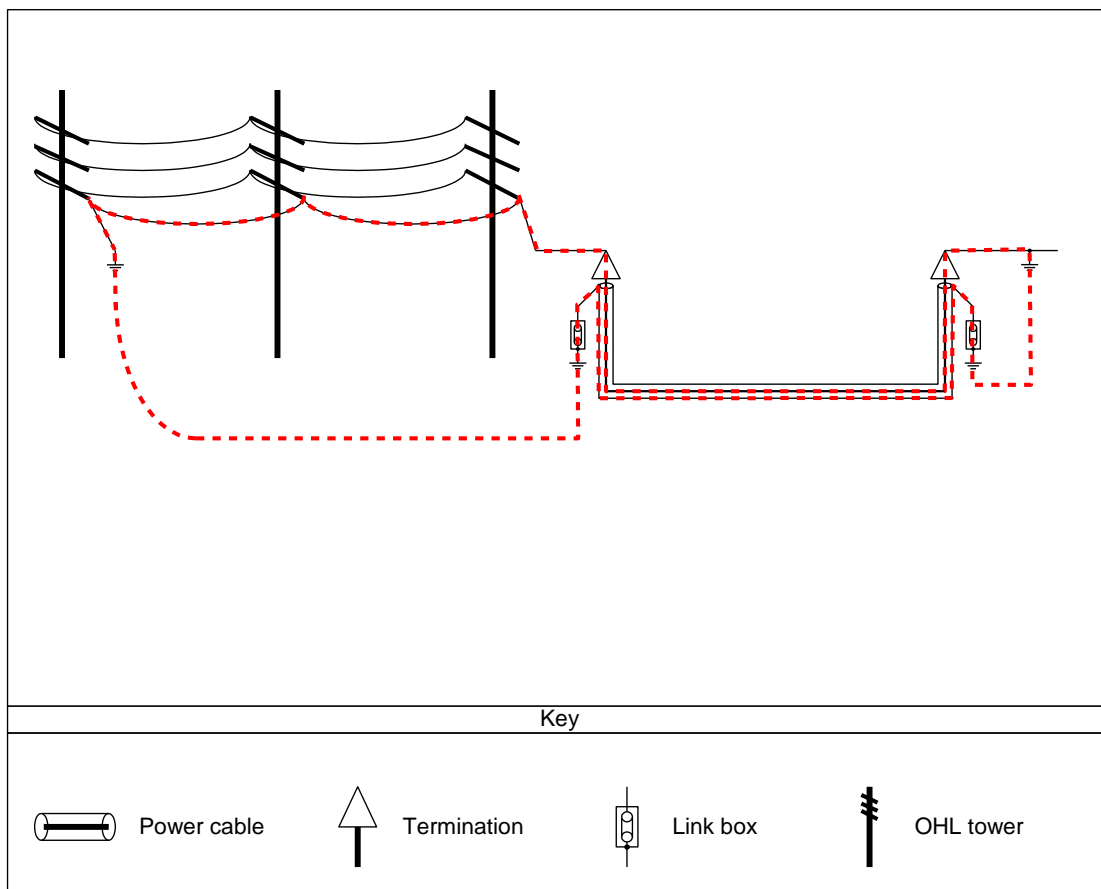

Figure 6 Stray current from connected OHL lines.

In Figure 6, an adjacent live overhead line circuit induces current in the out of service overhead line circuit (only one phase is shown for clarity). The induced current is forced through the cable conductor and then returns via the earth. A red dotted line shows the current path. The cable system shown has both ends of the sheath earthed so a considerable current will flow in the cable sheath as this is likely to be the lowest impedance path. This current in the sheath could be similar in size to the current in the conductor (up to 450A (900A in a complex circuit)). Equipment for NSI 5 working is not rated for this level of current and hence no work should be attempted for cables connected directly to overhead lines in this configuration.

For single point bonded systems where the sheaths are unearthed at one end, rather than current being induced in the sheath, a voltage will be induced. The sheath voltage limiters are rated so that they do not conduct during a single phase short circuit so the sheath voltages will withstand the voltage. However any attempt to work unearthed at these locations will be hazardous as any inadvertent earth will exceed the rating of the NSI 5 equipment. Hence work is not recommended with the circuit in this configuration.

For cross bonded systems, as the induced currents in the conductors of the cables are not likely to be balanced three phase, the amount of induced voltage and current is difficult to calculate. No work should be attempted for cables connected directly to overhead lines in this configuration.

By applying an earth between the cable system and the overhead line, the induced current in the overhead line will now return via the earth and not via the cable. This situation is shown in Figure 7.

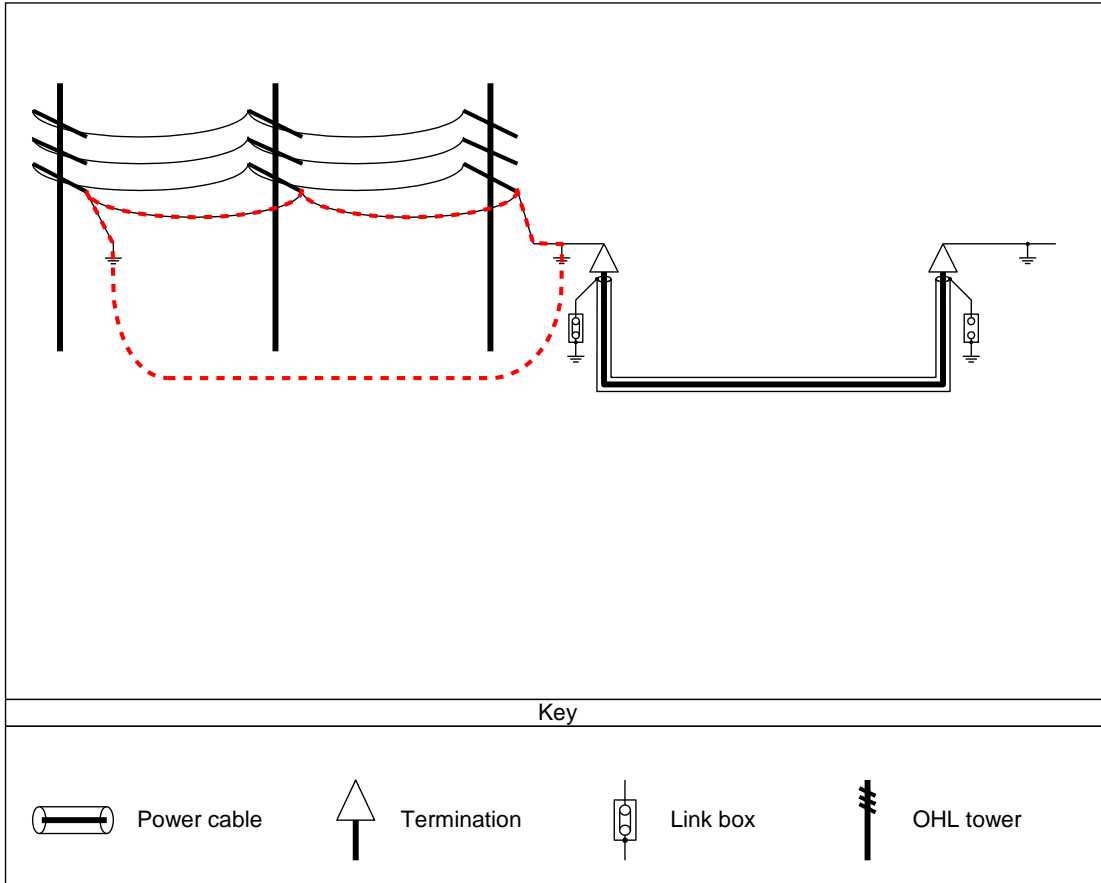
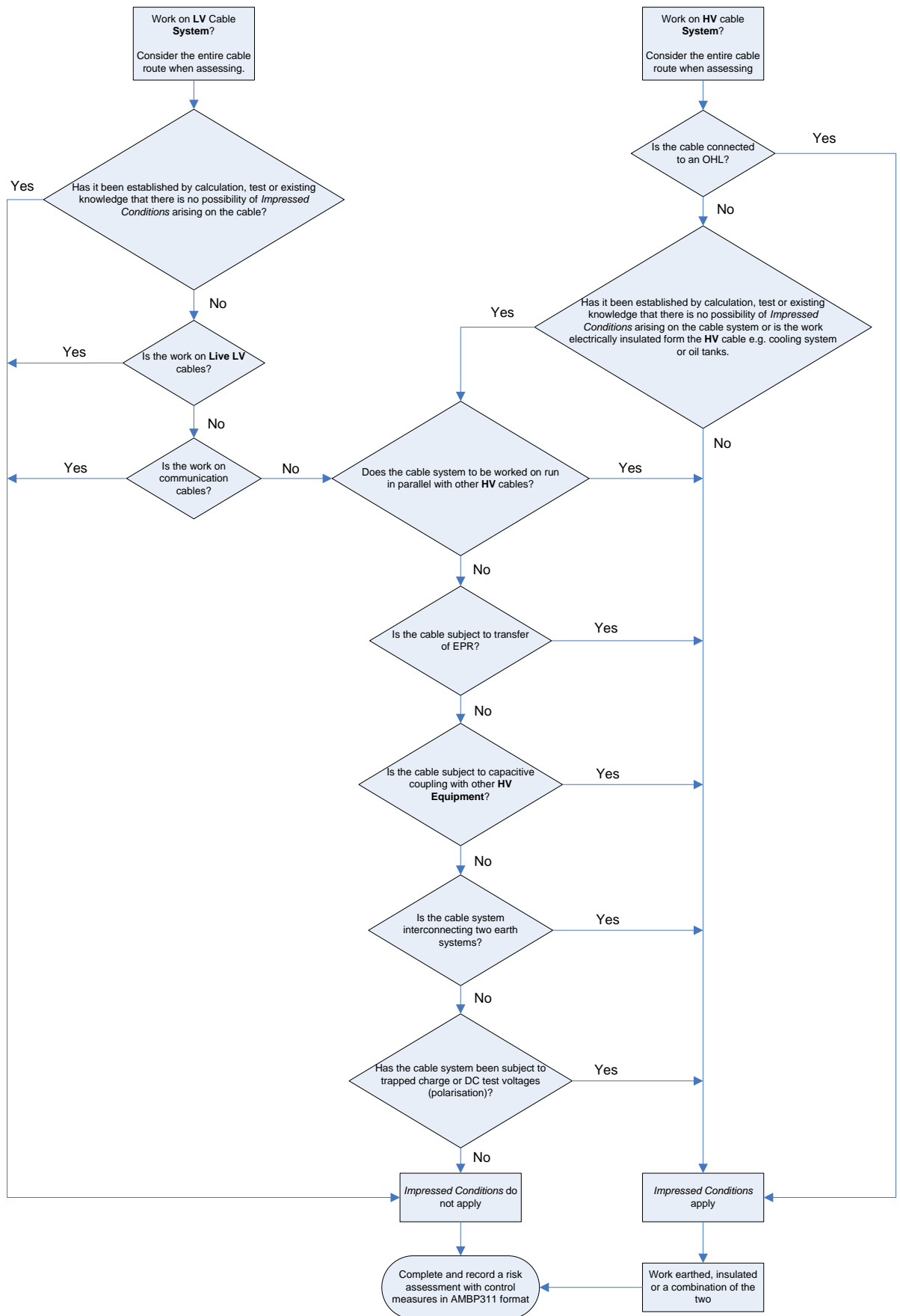

Figure 7 Earthed OHL lines.

Once an earth connection has been made between the cable and OHL, the risk from the induced current in the overhead lines is mitigated. The earth between the overhead line and cable system will need to meet the requirements of NSI 4.

Appendix 3 - Impressed Conditions Guidance When Working on Cable Systems.



Appendix 4 - Authorisation Matrix for Personnel

Non Company Personnel as defined in NSI 30	Person	Competent Person	Authorised Person	Senior Authorised Person
N/A	N/A	All Sections	N/A	All Sections

Non Company Personnel

Contractors by law have a duty to provide a safe system of work for their employees.

National Grid have a duty in law to employ competent contractors to undertake work on Cable Systems and provide them with National Grid’s safe system of work to enable them to develop their own safe systems of work.

National Grid Supply Chain Management processes ensure competent contractors are selected and therefore there is no requirement for authorisation under NSI 5.

Once a competent contractor is selected, National Grid has a duty to ensure the contractor understands **Danger(s)** associated with undertaking work within a **HV** compound, permit systems, demarcation and safe access and egress, including movement of objects and vehicles etc. This is accomplished by contractors employees being authorised to National Grid Safety Rules and to NSI 6 and 8, via Management Procedure - NSI 30 “Appointment of Persons”.

Before a **Safety Document** is issued the NSI 5 **Senior Authorised Person** shall establish **Safety from the System**. The contractors risk assessment and method statement shall be reviewed by the **Senior Authorised Person** to ensure the **Danger(s)** identified in NSI 5 are suitably managed.

The National Grid **Senior Authorised Person** will issue a **Safety Document** to a contractor’s **Competent Person** authorised to NSI 6 & 8.